

**BULHEAD JACK RECEPTACLE FOR PCB
COMBINATION SEAL - SOLDER LEGS**

R114.590.035

Series : SMB

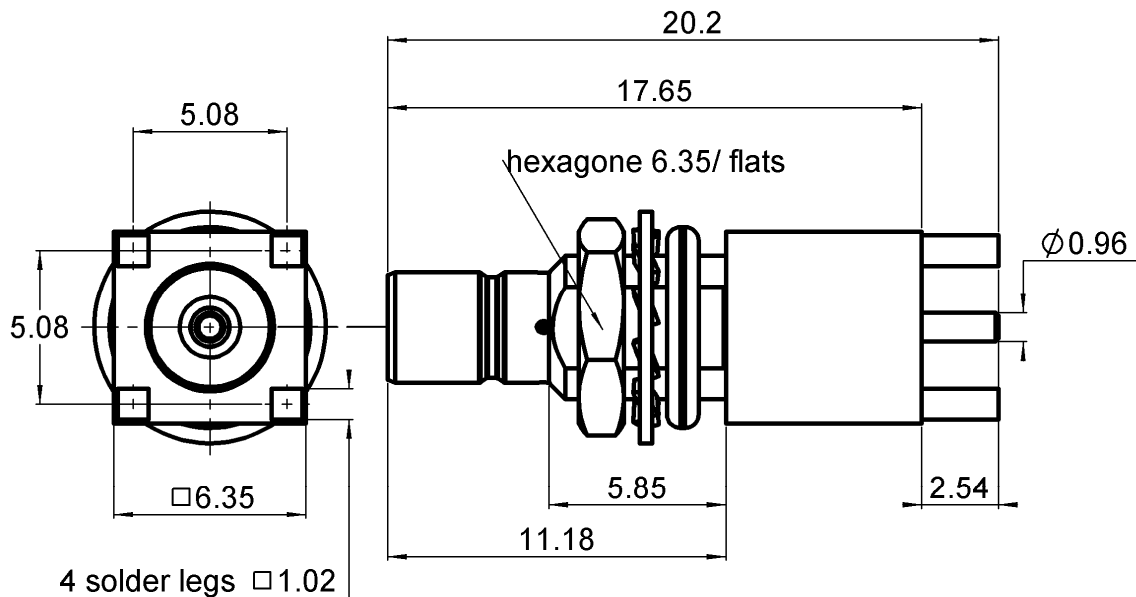

4 solder legs □1.02

PANEL CUT OUT

mm		
	Maxi	mini
A	5	4.9
B	4.55	4.45

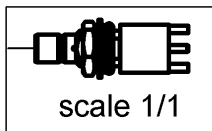

PANEL CUT OUT

A DIA
5 holes

mm		
	Maxi	mini
A	1.8	1.7
B	5.13	5.03

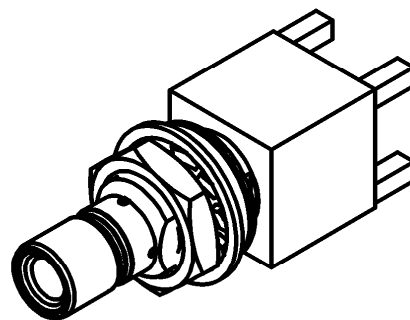

All dimensions are in mm.

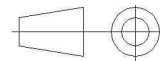

COMPONENTS	MATERIALS	PLATING (µm)
BODY	BRASS	NICKEL 2
CENTER CONTACT	BRASS	GOLD 1.3 OVER NICKEL2
OUTER CONTACT	-	-
INSULATOR	PTFE	-
GASKET	-	-
OTHERS PARTS	-	-
-	-	-
-	-	-

Issue : 0942 D

In the effort to improve our products, we reserve the right to make changes judged to be necessary.



**BULHEAD JACK RECEPTACLE FOR PCB
COMBINATION SEAL - SOLDER LEGS**

R114.590.035

Series : **SMB**

PACKAGING

Standard	Unit	Other
100	'W' option	Contact us

SPECIFICATION

ELECTRICAL CHARACTERISTICS

Impedance		50 Ω
Frequency		0-4 GHz
VSWR	1.05 +	0,0080 x F(GHz) Maxi
Insertion loss		0.03* √F(GHz) dB Maxi
RF leakage	- (57 - F(GHz)) dB Maxi
Voltage rating		500 Veff Maxi
Dielectric withstanding voltage		1000 Veff mini
Insulation resistance		1000 MΩ mini

ENVIRONMENTAL

Operating temperature	-65/+165 ° C
Hermetic seal	NA Atm.cm3/s
Panel leakage	.1193

OTHER CHARACTERISTICS

Assembly instruction

Others :

* COAXIAL TRANSMISSION LINE ONLY

MECHANICAL CHARACTERISTICS

Center contact retention		
Axial force – Mating end		10 N mini
Axial force – Opposite end		10 N mini
Torque		NA N.cm mini
Recommended torque		
Mating		NA N.cm
Panel nut		60 N.cm
Mating life		500 Cycles mini
Weight		2,5300 g

Issue : 0942 D

In the effort to improve our products, we reserve the right to make changes judged to be necessary.

RADIALL 